

Quick Solutions Multi-Function Detector

MFD Starter Kit (paging option)

Overview

This document outlines the QS Multi-Function Detector (MFD) starter kit with simple pager functionality. Designed for small sites without the need to integrate with CCTV, the system delivers a pager message whenever an MFD is triggered.

When a customer selects targeted products, MFDs communicate with the system and alert staff on the shop floor. Optional accessories include panic buttons and PIR detectors for the monitoring of enclosed spaces.

The system ensures that security staff are more focused and proactive in preventing loss, however there are also distinct sales and marketing benefits. Product pick up alerts can be used to direct sales staff to the shop floor to provide assistance.

If you require integration with existing CCTV equipment, you can purchase a CCTV integration version of this kit. Using digital alarm outputs you can program cameras to respond and send alerts to a podium. Further information can be obtained on our website at www.quicksolutions.co.uk/products.aspx.

Contact Details

Hawk Surveillance Systems Ltd t/a Quick Solutions

The Old School House
Manchester Road
Carrington
Manchester
M31 4UG

w: www.quicksolutions.co.uk
t: +44 (0)870 224 5647
e: sales@quicksolutions.co.uk

System components

A typical system consists of the following components

- 4x Multi-Function Detectors (MFDs)
- 1x MFD Receiver box

- 1x MFD battery charger
- 1x MFD remote control
- 1x Pager transmitter unit
- 1x Pager

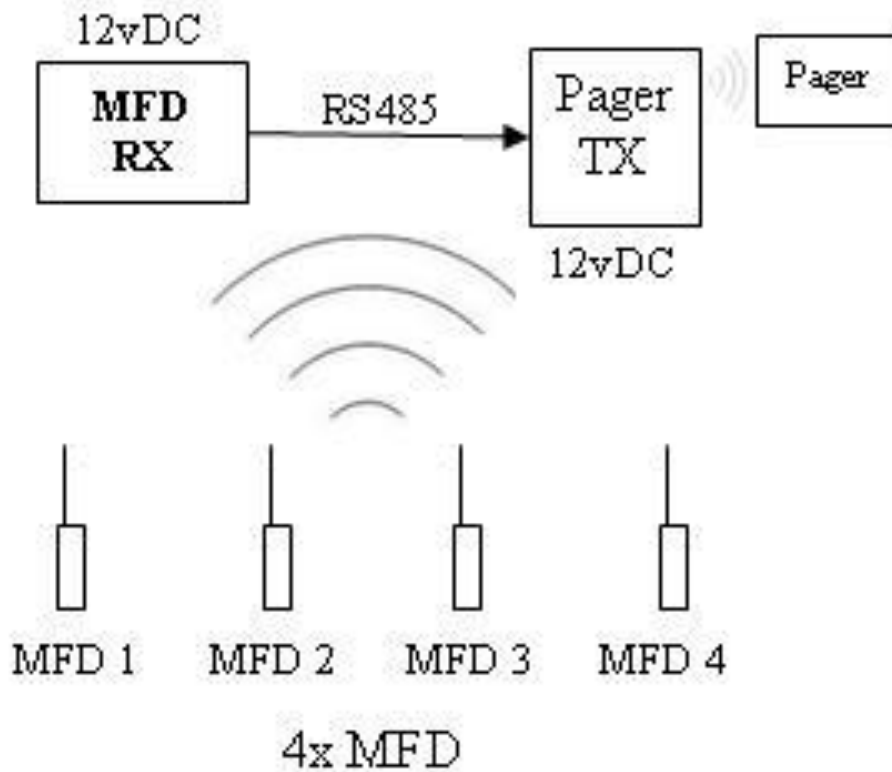

Figure 1. System schematic

The MFD receiver boxes should be positioned on the shop floor and evenly distributed to ensure maximum coverage. A MFD can be positioned up to 200m from the receiver unit, dependent on other radio signals in the area, walls and other infrastructure. The receiver communicates with the interface unit via RS485. Multiple receiver units can be connected in series to widen store coverage.

The MFD

The Quick Solutions MFD is a battery powered radio transmitter unit containing a passive infra-red sensor. A signal is transmitted on motion detection to initiate camera recordings and/or notify a pager system.

The device is fitted with two strong magnets for secure positioning underneath shelving, and a fixture for strapping to posts etc.

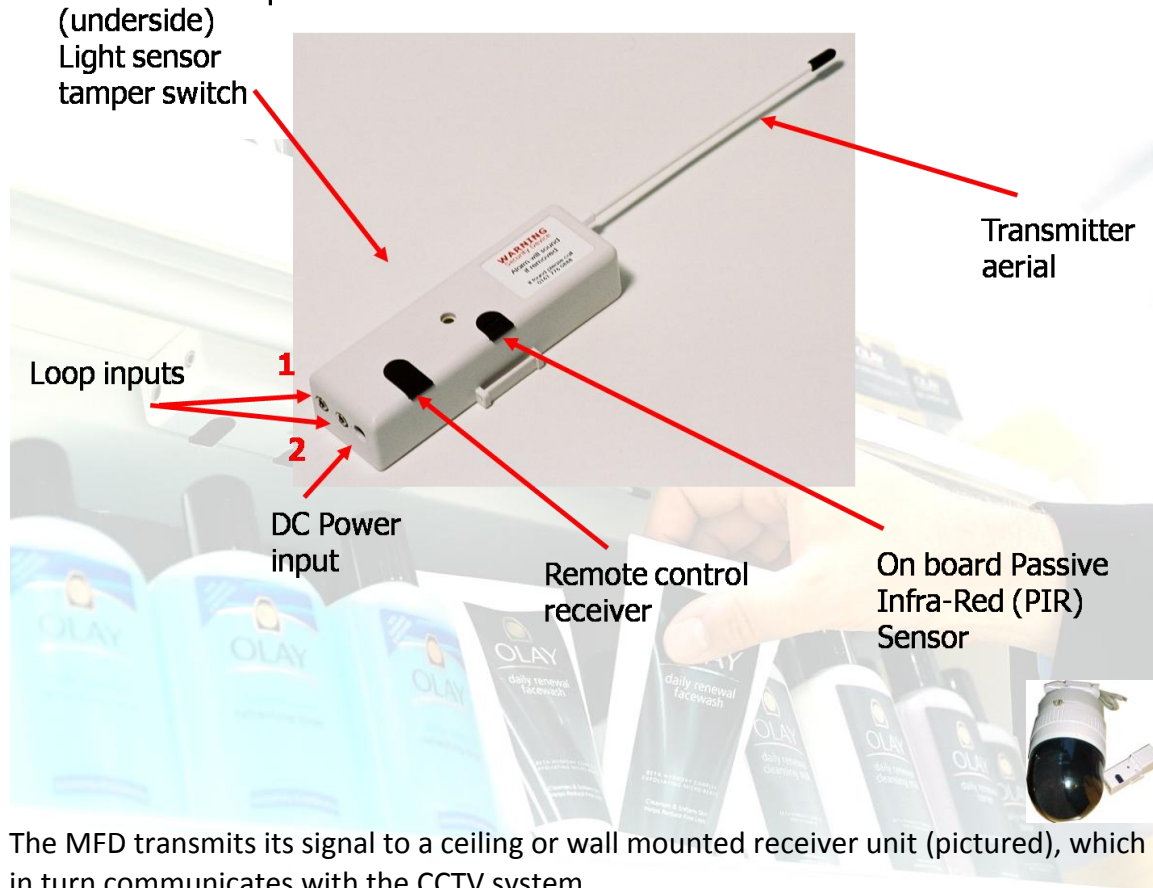

The MFD transmits its signal to a ceiling or wall mounted receiver unit (pictured), which in turn communicates with the CCTV system.

Technical Specifications

- Frequency FM 433MHz
- 3 mW RF power
- 600m signal range
- Light sensitive tamper switch
- Audible alarm deterrent on tamper
- Periodic battery status transmission enabling monitoring
- Rechargeable battery with up to 60 day life
- 2 loop input sockets capable of responding to any circuit with a 3.5mm jack plug
- Remote control handset

- Easy and fast to deploy

Support and Warranty

Telephone technical support is available from our engineers between 9am and 5pm Monday-Friday on **0870 224 5647** (excluding bank holidays).

All equipment carries a 12 month collect and return warranty.

Out of warranty repairs are charged on a parts and labour basis. On site repairs will incur a call out charge.

Customers can also email technical support on techsupport@quicksolutions.co.uk. We endeavour to respond to all enquiries within 24 hours.

Customers also have access to a wealth of online resources on the website at www.quicksolutions.co.uk. The support section includes a dedicated customer workspace for delivery of announcements, software updates and user guides.

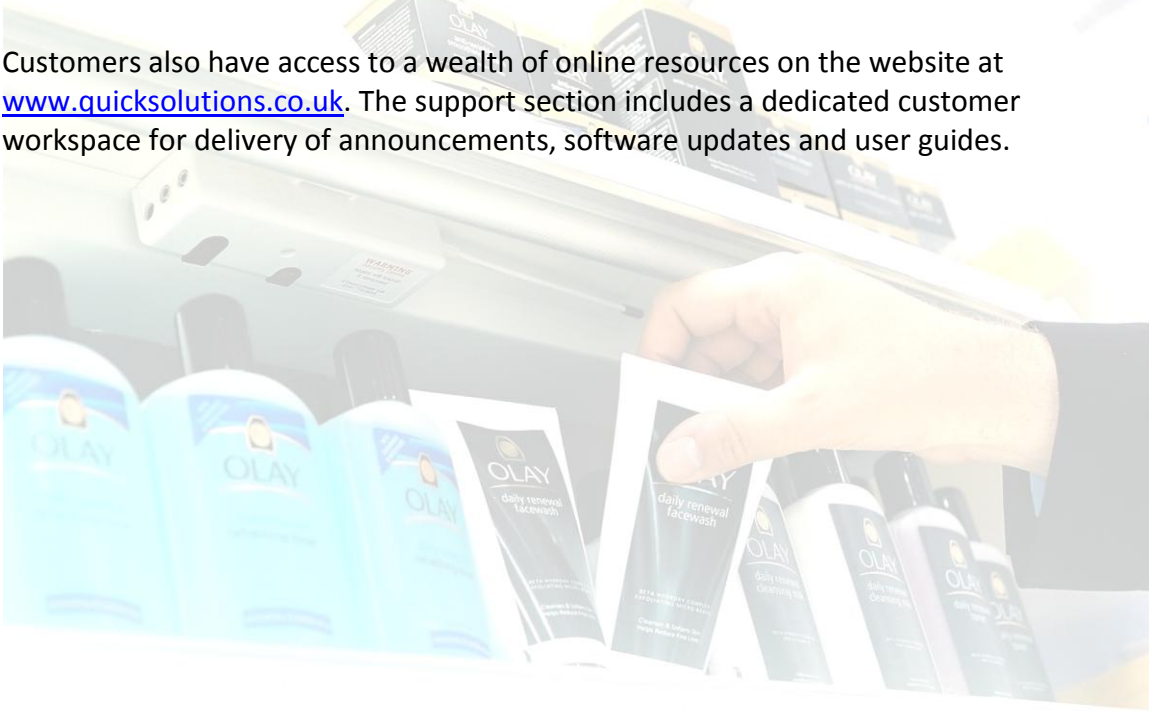

Warranty Statement

1. Quick Solutions warrants that for a set period, valid from the date of invoice, its products are free from any defects in work and materials.
2. The warranty period for hardware varies between products. For product specific warranty details please visit the Quick Solutions website or contact Quick Solutions on 0870 224 5647.
 - a. The hardware warranty period covers all components of the product including the Hard Disk Drives, unless otherwise stated.
3. The warranty excludes any and all defects arising from: drawing, design, specification or requirement of the Customer, general fair wear and tear, willful damage, negligence, accidental damage, abnormal working conditions (including moisture and temperature fluctuations outside the recommended operating window), failure to follow Product environment, installation and operating instructions, acts of nature, voltage fluctuations and as a result of connection to or a location near any third party equipment.
4. Any stored data is not covered under this warranty. Although every attempt shall be made to recover stored footage in the event of failure, Quick Solutions bears no liability with regards to the loss of data held in the unit.
5. The warranty shall be invalid if:
 - a. The serial number label is damaged and / or illegible
 - b. The product has been opened, tampered with or previously repaired by an unapproved engineer.
 - c. The product has not been installed in accordance with the Installation Guidelines.
6. To ensure the warranty remains valid, all repairs must be conducted by a Quick Solutions approved Engineer. Contact Quick Solutions on 0870 224 5647 for a returns authorisation number
7. On discovery of any defect or non-conformity of the product covered by a warranty, the customer must notify Quick Solutions as soon as reasonably possible. Quick Solutions shall have no liability in respect to the product under warranty (or any other warranty, condition or guarantee) unless notification is received prior to the expiry of the relevant warranty period.
8. Repairs on products under warranty will normally be conducted free of charge (as long as the conditions described in sections 4, 5, 6 & 7 are adhered to) The cost of shipping the faulty unit to Quick Solutions for repair will be funded by the customer. The cost of shipping the repaired unit from Quick Solutions to the customer's premises will normally be covered by the warranty. Quick Solutions retains the right to charge for special shipping arrangements or delivery to alternative premises. The charge will be at cost and made at Quick Solutions' discretion. Quick Solutions will not be liable for any costs incurred during the removal and reinstallation of the equipment. This includes all travel, labour and equipment-hire expenses that may be incurred.
9. For on-site repairs, the customer shall provide Quick Solutions with a suitable working environment. Failure to provide a suitable working environment for Quick Solutions engineers shall result in postponement of work until suitable working conditions can be provided, providing work can still take place within the warranty period.
10. Following a product repair, Quick Solutions will warrant that product to the end of the original warranty period.
11. Should the part that is returned be out of warranty, Quick Solutions will charge for labour and parts accordingly. Contact Quick Solutions on 0870 224 5647 for pricing. Repaired products that are out of warranty will be given a 12 month warranty on the affected part / component only.
12. If a Customer fails to comply with the Terms and Conditions laid out in this document, and including, but not limited to, the time of performance in relation to such matters as payment then, without prejudice to all other rights of Quick Solutions, the warranties contained in this document and Quick Solutions standard Terms and Conditions shall from the date of such non-performance terminate and for the purpose of this Contract shall be deemed as excised.